

INFV-1000-V2

INFRARED TEMPERATURE SENSOR
1000°C

S/N:

Texys sensors are designed for data recording. If the user wants to include this sensor in a close loop system or active control, he must assume all responsibility.

Range	1000	°C
Accuracy*	1% FS	
Resolution at 1000°C	15	mV/°C
Response time	50	ms
Supply Voltage	5 to 16	V
Supply Current	1,5	mA
Output signal	0-5	V
Sensitive Element	Thermopile with Silicium Lens	
Wave Length	8 to 14	µm
Measurement distance	30 to 100	mm
Field of view (90% radiation)	5 : 1 at 50mm	
Calibrator	Land R1200P	
Emissivity	99%	
Dimensions	M12 x 1 x length 32	mm
Material	Aluminium	
Weight (without cable)	15	g
Protection	IP64	
Vibration test	20Gpp 5'	
Shock	500	G
Operating Temp	-20 to +150	°C
Storage Temp	-40 to +150	°C

*for ambient temperature between 0°C and 100°C
and for target > 300°C

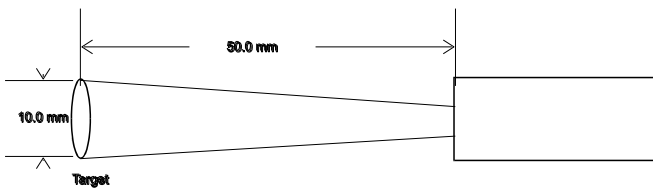

Sensor readings
V at 25 °C
V at 1000 °C

Cable :
 3X26AWG FEP tinned copper braided cable 250V 200°C
 EPD 117723A
 Length : 1000 mm Tubing :
 Connector :

Colour	Function	Pin
Red	5-16 V	
White or Yellow	Signal	
Black	0 V	
Braid (not for EPD 117723A)		

Calibration table		
° C	Volts / Steel	Volts / Carbon
0	0.00	0.00
100	0.02	0.02
200	0.07	0.08
300	0.14	0.18
400	0.27	0.36
500	0.49	0.63
600	0.84	1.03
700	1.34	1.60
800	2.02	2.37
900	2.89	3.39
1000	4.01	4.71

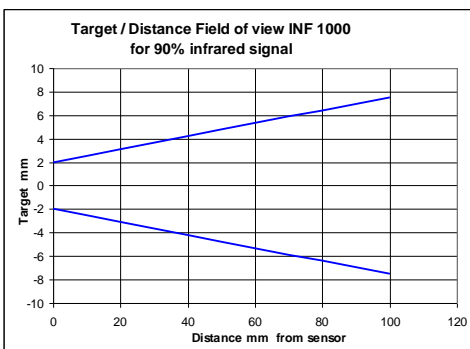
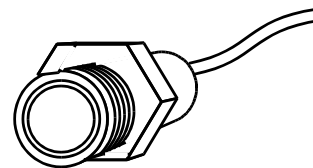
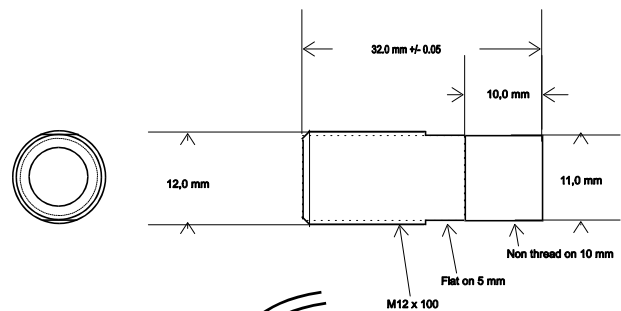

Warning: the metallic ring around the lens is connected inside the sensor. Avoid any electrical

