

**INFT-1000-V2**  
 INFRARED TEMPERATURE SENSOR 1000°C  
 Ref :  
 SN :

Texys sensors are designed for data recording. If the user wants to include this sensor in a close loop system or active control, he must assume all responsibility.

Sensor readings	
V at 25°C	
V at 1000°C	

Range	1000	°C
Accuracy*	1% FS	
Resolution at 1000°C	15	mV/°C
Response time	50	ms
Supply Voltage	5 to 16	V
Supply Current	1,5	mA
Output signal	0-5	V
Sensitive Element	Thermopile with Silicium Lens	
Wave Length	8 to 14	µm
Measurement distance	30 to 100	mm
Field of view (90% radiation)	5 : 1 at 50mm	
Calibrator	Land R1200P	
Emissivity	99%	
Dimensions	27x17x11	mm
Material	Aluminium	
Weight (without cable)	15	g
Protection	IP64	
Vibration test	20Gpp 5'	
Shock	500	G
Operating Temp	-20 to +150	°C
Storage Temp	-40 to +150	°C

\*for ambient temperature between 0°C and 100°C and for target > 300°C

Calibration table		
° C	Volts Steel	Volts Carbon
0	0.00	0.00
100	0.02	0.02
200	0.07	0.08
300	0.14	0.18
400	0.27	0.36
500	0.49	0.63
600	0.84	1.03
700	1.34	1.60
800	2.02	2.37
900	2.89	3.39
1000	4.01	4.71

Cable :  
 3X26AWG FEP tinned copper braided cable 250V 200°C  
 EPD 117723A  
 Length : ..... mm    Tubing : .....  
 Connector : .....

Colour	Function	Pin
Red	5-16 V	
White or Yellow	Signal	
Black	0 V	
Braid (not for EPD 117723A)		

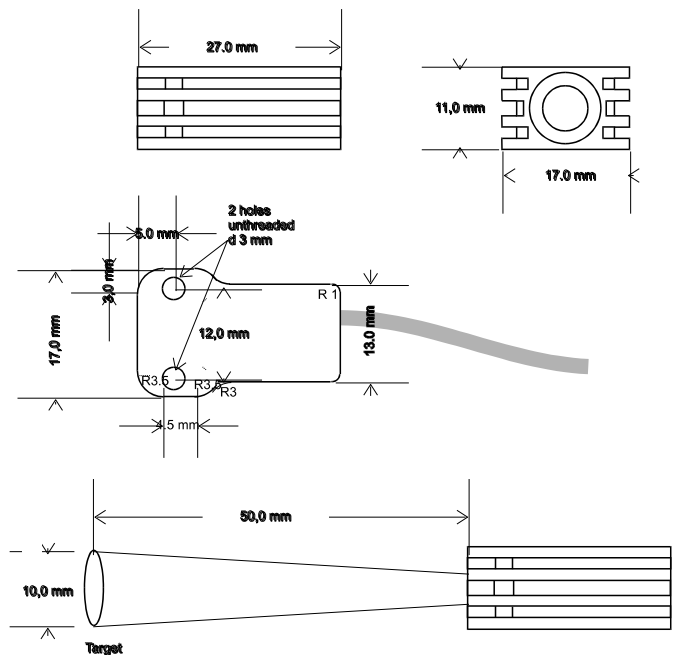

Warning: the metallic ring around the lens is connected inside the sensor. Avoid any electrical

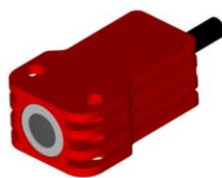
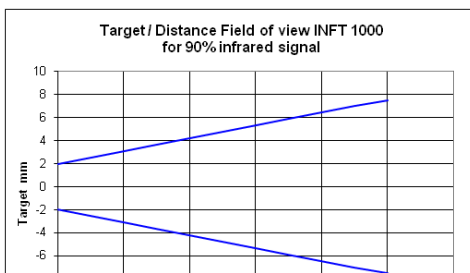

Standard

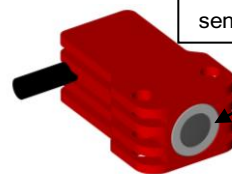

Right Angle version

Ordering ref ex : INFT  
 1000-V2 INFT 1000-V2-version